

- It can be used for all liquids and vapors in the fields of chemical and pharmaceutical industries and in all other applications outside the operating limits of gasketed PHE's
- Welded stainless steel frame and bolt-in version
- Chevron corrugation patterns
 - H - plate of High heat transfer
 - W- plate of Low pressure drop
 - HW – mixing H and W plate
- Approval : PED97/23EC, ASME

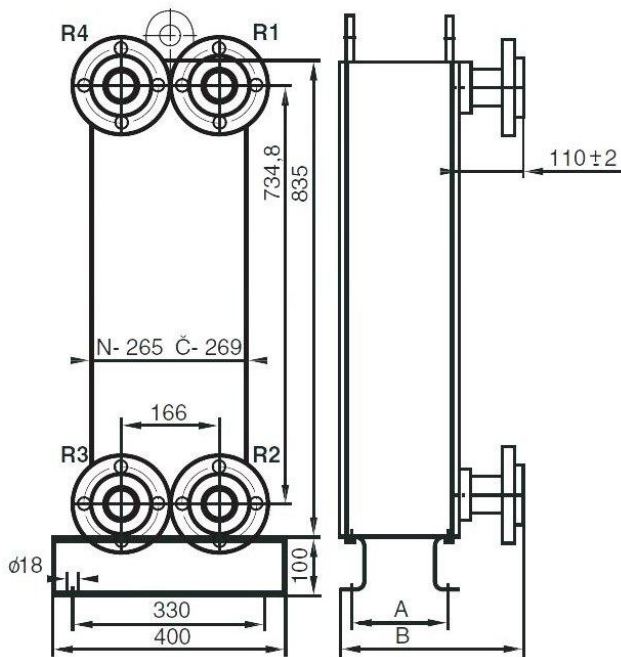

Length A	100 to 385 mm
Length B	230 to 495 mm

Operating and Technical parameters	
Temperature	-40°C up to 250°C
Pressure	up to 25 bar and higher
Flow	up to 35 m ³ /h
Heat Transfer Surface	up to 25,3 m ²
Connection Sizes	DN 50 (2")
	Stud Bolts
	Aseptic Connections
	Flange
	Threaded
	Pipe thread



Plate Material	
Standard	1.4301 (AISI 304)
	1.4404 (AISI 316 L)
	1.4571 (AISI 316 Ti)
Special	1.4539 (AISI 904 L)
	1.4547 (SMO 254)
	Nickel Alloys
	Titan
	Titan-Pd

Frame	
	Painted Carbon Steel
	Stainless Steel

Connections	
Standard	1.4571 (AISI 316 Ti)
Special	Nickel Alloys
	Titan
	Titan-PD

For the calculation of Heat Exchanger type, for the given application is a comprehensive software available. If necessary, Design of Heat Exchanger will be calculate immediately for a given application, available to be performed with high accuracy using our calculation tools, based on extensive thermodynamic and hydrodynamic measurements.

Calculation is based on these parameters :

- Operating Temperature program
- Flow rate or Heatload
- Operating pressure, Allowable Pressure drop
- Flow medium or Physical properties



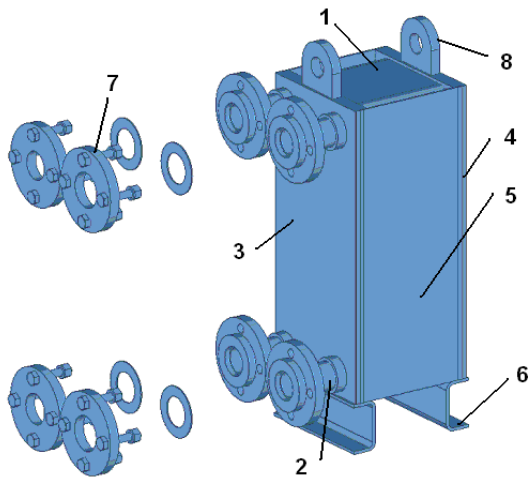

Complete Welded design

- 1. - Welded heat transfer plate packet
- 2. - Connections
- 3. - Front cover plate
- 4. - Back cover plate
- 5. - Side plate
- 6. - Mounting bracket
- 7. - Counterflange (supplied on request)
- 8. - Hanger (handling eye)

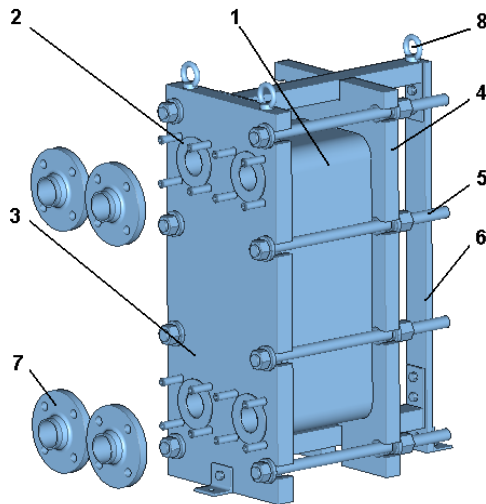

Frame-bolt design

- 1. - Welded heat transfer plate packet
- 2. - Connections
- 3. - Front cover plate
- 4. - Back cover plate
- 5. - Tightening bar
- 6. - Mounting bracket
- 7. - Counterflange (supplied on request)
- 8. - Hanger (handling eye)

MARKING – CODES (Example)

Marking of **Welded design** **WST18-80-1/1-VNP01**
 1 2 3 4 5

- 1. **WST** - type of heat exchanger
- 2. **18** - size of plate
- 3. **80** - number of heat transfer plate
- 4. **1/1** - number of passes (channel 1 / channel 2)
- 5. 1.pos. Pressure level
 N - up to 10 bara
 V - up to 25 bara
 H - more than 25 bara
2.pos. Material of shell
 N – shell of Austenitic Stainless steel (shot blasting - surface is polished with glass beads)
 D – shell of Duplex Stainless steel
 C – shell of Carbon steel - painted
3.pos. Type of connection
 A – atypical (custom made) connection
 P – with Flanges
 Z – with Threaded connections
4.pos. Additional information about Heat Exchanger (welded neck flanges, rings with grooves, connection with expansion joints etc)

Marking of **Frame-bolt design** **WST18-80-1/1-TBL**
 1 2 3 4 5

- 1. **WST** - type of heat exchanger
- 2. **18** - size of plate
- 3. **80** - number of heat transfer plate
- 4. **1/1** - number of passes (channel 1 / channel 2)
- 5. 1.pos. Pressure design
 T – with gasket ring
2.pos. Pressure level
 B - up to 10 bara
 D - up to 25 bara
3.pos. Material of shell
 L – shell of Carbon steel - painted
 N – shell of Austenitic Stainless steel (shot blasting - surface is polished with glass beads)

Note:
 Variants of shell and connecting is possible combine.

